



## 钨钢磨头

Carbide Bit

# 钨钢美甲磨头规格 Carbide Bit Specifications

Coarseness: 齿密度

	Super Coarse 五倍极粗齿	5XC
	Ultra Coarse 四倍特粗齿	4XC
	Triple Coarse 三倍特粗齿	3XC
	Double Coarse 两倍特粗齿	XXC
	Extra Coarse 超粗齿	XC

	Coarse 粗齿	C
	Medium 标准齿	M
	Fine 细齿	F

	Extra Fine 超细齿	XF
	Double Fine 两倍特细齿	XXF
	Triple Fine 三倍特细齿	3XF

Flute Diameter (D) 刃径  
Cut 切削: Yes是 No否

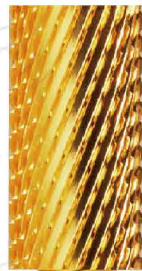



Coating 镀层:

None 无镀层	
Silver 银色	
Gold 金色	
Blue Nano 蓝纳米	
TIN 氮化钛	
ROSY Gold 玫瑰金	
Rain bow 彩色	
Purple 紫色	
DC 金刚石	

 For Left Hand  
左手

 For Right Hand  
右手

  For Left and Right Hand  
左右手

Shank Diameter 柄径:  
3/32" (2.35mm)  
1/8" (3.175mm)

柄长  
Shank Length

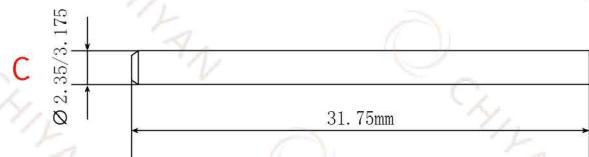
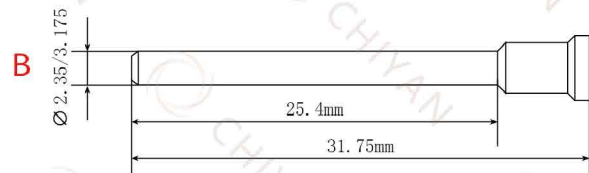
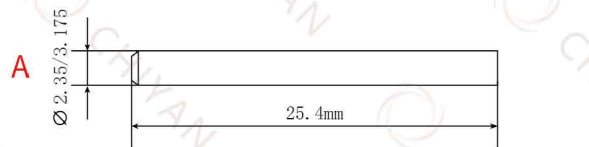

标准柄  
Standard Shank

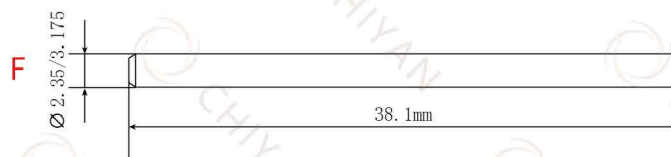
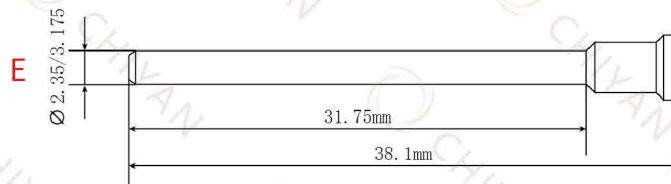
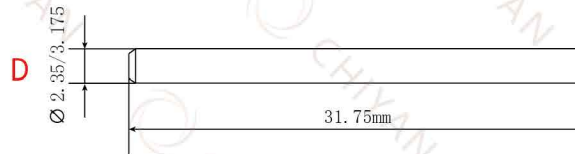

长柄  
Long Shank

## Large Barrel Bit 6.60mm直筒平头

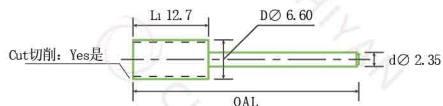

密度 Coarseness	Super Coarse 5XC	Ultra Coarse 4XC	Triple Coarse 3XC	Double Coarse XXC	Extra Coarse XC	Coarse C	Medium M	Fine F	Extra Fine XF	Double Fine XXF	Triple Fine 3XF
订单编号 Order No.	T00404C5	T00424C4	T00424C3	T00424C2	T00424C1	T00424C0	T00424M0	T00424F0	T00424F1	T00424F2	T00424F3

## Large Barrel Bit (Chamfer) 6.60mm直筒平头 (倒角)

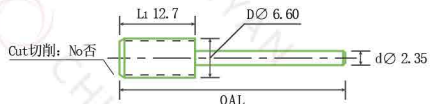

密度 Coarseness	Super Coarse 5XC	Ultra Coarse 4XC	Triple Coarse 3XC	Double Coarse XXC	Extra Coarse XC	Coarse C	Medium M	Fine F	Extra Fine XF	Double Fine XXF	Triple Fine 3XF
订单编号 Order No.	T01904C5	T01924C4	T01924C3	T01924C2	T01924C1	T01924C0	T01924M0	T01924F0	T01924F1	T01924F2	T01924F3

**Crystal Large Barrel Bit (Corner Radius) 6.60mm带钻直筒平头 (圆角)**

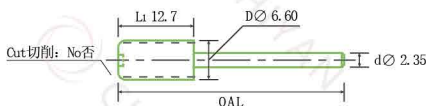

密度 Coarseness	Ultra Coarse 4XC	Triple Coarse 3XC	Double Coarse XXC	Extra Coarse XC	Coarse C	Medium M	Fine F	Extra Fine XF	Double Fine XXF
订单编号 Order No.	T04624C4	T04624C3	T04624C2	T04624C1	T04624C0	T04624M0	T04624F0	T04624F1	T04624F2

**Crystal Large Barrel Bit (R Cut) 6.60mm带钻直筒平头 (R角)**

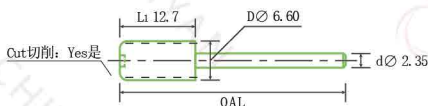

密度 Coarseness	Ultra Coarse 4XC	Triple Coarse 3XC	Double Coarse XXC	Extra Coarse XC	Coarse C	Medium M	Fine F	Extra Fine XF	Double Fine XXF
订单编号 Order No.	T05524C4	T05524C3	T05524C2	T05524C1	T05524C0	T05524M0	T05524F0	T05524F1	T05524F2

## Large Barrel Smooth Top Bit 6.60mm直筒光头

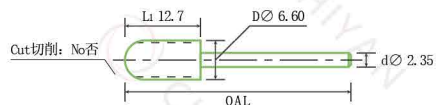

密度 Coarseness	Ultra Coarse 4XC	Triple Coarse 3XC	Double Coarse XXC	Extra Coarse XC	Coarse C	Medium M	Fine F	Extra Fine XF	Double Fine XXF	
订单编号 Order No.	T07624C4	T07624C3	T07624C2	T07624C1	T07624C0	T07624M0	T07624F0	T07624F1	T07624F2	

## Large Rounded Top Bit 6.60mm直筒球头

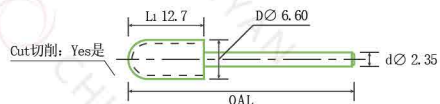

密度 Coarseness	Ultra Coarse 4XC	Triple Coarse 3XC	Double Coarse XXC	Extra Coarse XC	Coarse C	Medium M	Fine F	Extra Fine XF	Double Fine XXF	
订单编号 Order No.	T09624C4	T09624C3	T09624C2	T09624C1	T09624C0	T09624M0	T09624F0	T09624F1	T09624F2	

**Small Barrel Bit 5.35mm直筒平头**

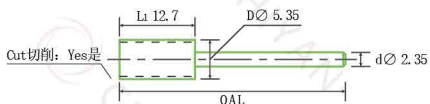

密度 Coarseness	Super Coarse 5XC	Ultra Coarse 4XC	Triple Coarse 3XC	Double Coarse XXC	Extra Coarse XC	Coarse C	Medium M	Fine F	Extra Fine XF	Double Fine XXF	Triple Fine 3XF
订单编号 Order No.	T00204C5	T00224C4	T00224C3	T00224C2	T00224C1	T00224C0	T00224M0	T00224F0	T00224F1	T00224F2	T00224F3

**Small Barrel Bit (Chamfer) 5.35mm直筒平头 (倒角)**

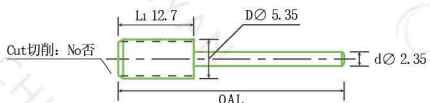

密度 Coarseness	Super Coarse 5XC	Ultra Coarse 4XC	Triple Coarse 3XC	Double Coarse XXC	Extra Coarse XC	Coarse C	Medium M	Fine F	Extra Fine XF	Double Fine XXF	Triple Fine 3XF
订单编号 Order No.	T01704C5	T01724C4	T01724C3	T01724C2	T01724C1	T01724C0	T01724M0	T01724F0	T01724F1	T01724F2	T01724F3

### Crystal Small Barrel Bit (Corner Radius) 5.35mm带钻直筒平头 (圆角)

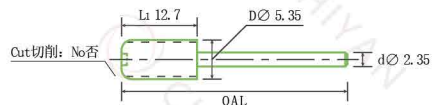

密度 Coarseness	Ultra Coarse 4XC	Triple Coarse 3XC	Double Coarse XXC	Extra Coarse XC	Coarse C	Medium M	Fine F	Extra Fine XF	Double Fine XXF	
										
订单编号 Order No.	T04524C4	T04524C3	T04524C2	T04524C1	T04524C0	T04524M0	T04524F0	T04524F1	T04524F2	

### Crystal Small Barrel Bit (R Cut) 5.35mm带钻直筒平头 (R角)

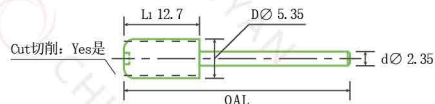

密度 Coarseness	Ultra Coarse 4XC	Triple Coarse 3XC	Double Coarse XXC	Extra Coarse XC	Coarse C	Medium M	Fine F	Extra Fine XF	Double Fine XXF	
										
订单编号 Order No.	T05424C4	T05424C3	T05424C2	T05424C1	T05424C0	T05424M0	T05424F0	T05424F1	T05424F2	

钨钢磨头  
Carbide Bit



**Small Barrel Smooth Top Bit 5.35mm直筒光头**

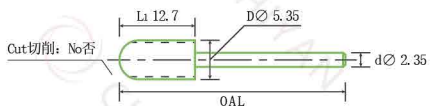

密度 Coarseness	Ultra Coarse 4XC	Triple Coarse 3XC	Double Coarse XXC	Extra Coarse XC	Coarse C	Medium M	Fine F	Extra Fine XF	Double Fine XXF	
订单编号 Order No.	T07324C4	T07324C3	T07324C2	T07324C1	T07324C0	T07324M0	T07324F0	T07324F1	T07324F2	

**Small Rounded Top Bit 5.35mm直筒球头**

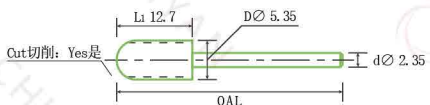

密度 Coarseness	Ultra Coarse 4XC	Triple Coarse 3XC	Double Coarse XXC	Extra Coarse XC	Coarse C	Medium M	Fine F	Extra Fine XF	Double Fine XXF	
订单编号 Order No.	T09324C4	T09324C3	T09324C2	T09324C1	T09324C0	T09324M0	T09324F0	T09324F1	T09324F2	

### 3 Way



刃 径 Dmm	6.60	5.35
		
订单编号 Order No.	T00432M0	T00232M0

### Big Barrel Bit 8.0mm直筒平头

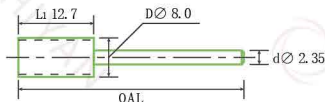

密度 Coarseness	Coarse C	Medium M	Fine F
			
订单编号 Order No.	T00524C0	T00524M0	T00524F0

### Super Big Barrel Bit 9.5mm直筒平头

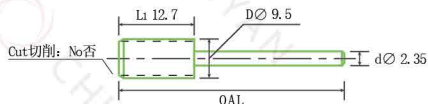

密度 Coarseness	Coarse C	Medium M	Fine F
			
订单编号 Order No.	T00624C0	T00624M0	T00624F0



钨钢磨头  
Carbide Bit

### Small Pink & White Bit 5.35mm端齿

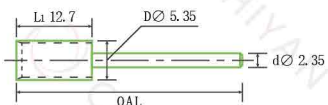

密度 Coarseness	Coarse C	Medium M	Fine F	
订单编号 Order No.	T11424C0	T11424M0	T11424F0	

### Large Pink & White Bit 6.60mm端齿

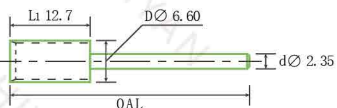

密度 Coarseness	Extra Coarse XC	Coarse C	Medium M	Fine F	
订单编号 Order No.	T11624C1	T11624C0	T11624M0	T11624F0	

## Big Pink & White Bit 8.0mm端齿

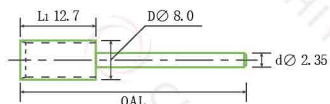

密度 Coarseness	Coarse C	Medium M	Fine F	
订单编号 Order No.	T11724C0	T11724M0	T11724F0	

## Super Big Pink & White Bit 9.5mm端齿

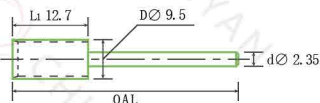

密度 Coarseness	Coarse C	Medium M	Fine F	
订单编号 Order No.	T11824C0	T11824M0	T11824F0	

3 In 1 三合一

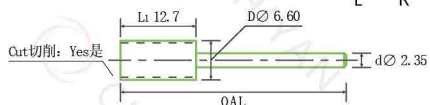

密度 Coarseness	Triple Coarse 3XC	Double Coarse XXC	Extra Coarse XC	Coarse C	Medium M	Fine F	Extra Fine XF
订单编号 Order No.	T03425C3	T03425C2	T03425C1	T03425C0	T03425M0	T03425F0	T03425F1

7.0mm 5 In 1 7.0mm五合一

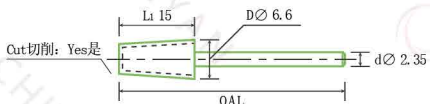

密度 Coarseness	Triple Coarse 3XC	Double Coarse XXC	Extra Coarse XC	Coarse C	Medium M	Fine F	Extra Fine XF	Double Fine XXF
订单编号 Order No.	T35725C3	T35725C2	T35725C1	T35725C0	T35725M0	T35725F0	T35725F1	T35725C2

6.0mm 5 in 1 6.0五合一

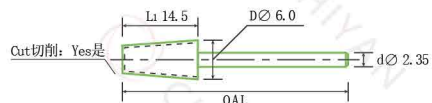

密度 Coarseness	Triple Coarse 3XC	Double Coarse XXC	Extra Coarse XC	Coarse C	Medium M	Fine F	Extra Fine XF	Double Fine XXF	
订单编号 Order No.	T35625C3	T35625C2	T35625C1	T35625C0	T35625M0	T35625F0	T35625F1	T35625F2	

5.2mm 5 in 1 5.2mm五合一

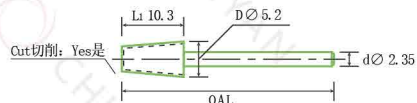

密度 Coarseness	Extra Coarse XC	Coarse C	Medium M	Fine F	Extra Fine XF	
订单编号 Order No.	T35525C1	T35525C1	T35525C1	T35525C1	T35525C1	

7.0mm 5 in 1 Cross Cut Bit 7.0mm五合一交叉齿

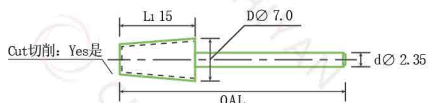

密度 Coarseness	Triple Coarse 3XC	Double Coarse XXC	Extra Coarse XC	Coarse C	Medium M	Fine F	Extra Fine XF	Double Fine XXF
订单编号 Order No.	T35723C3	T35723C2	T35723C1	T35723C0	T35723M0	T35723F0	T35723F1	T35723F2

6.0mm 5 in 1 Cross Cut Bit 6.0mm五合一交叉齿

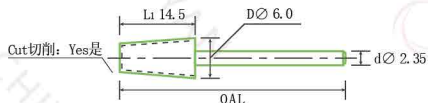

密度 Coarseness	Triple Coarse 3XC	Double Coarse XXC	Extra Coarse XC	Coarse C	Medium M	Fine F	Extra Fine XF	Double Fine XXF
订单编号 Order No.	T35623C3	T35623C2	T35623C1	T35623C0	T35623M0	T35623F0	T35623F1	T35623F2



series  
coarser and  
sharper cut





**SC 6.0mm Tapered Barrel R Cut (Cross Cut) Bit** 6.0mm锥形平头R角交叉SC齿

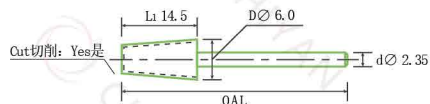

密度 Coarseness	Triple Coarse 3XC	Double Coarse XXC	Extra Coarse XC	Coarse C	Medium M	Fine F	
订单编号 Order No.	T35631C3	T35631C2	T35631C1	T35631C0	T35631M0	T35631F0	

**SC 7.0mm Tapered Barrel R Cut (Straight Cut) Bit** 7.0mm锥形平头R角直槽SC齿

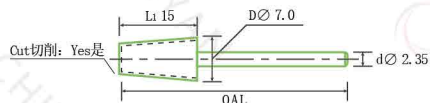

密度 Coarseness	Triple Coarse 3XC	Double Coarse XXC	Extra Coarse XC	Coarse C	Medium M	Fine F	
订单编号 Order No.	T35733C3	T35733C2	T35733C1	T35733C0	T35733M0	T35733F0	

## SC 7.0mm Tapered Barrel R Cut (Cross Cut) Bit 7.0mm锥形平头R角交叉SC齿

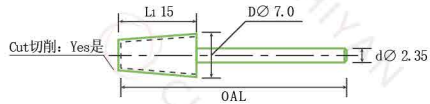

密度 Coarseness	Triple Coarse 3XC	Double Coarse XXC	Extra Coarse XC	Coarse C	Medium M	Fine F	
订单编号 Order No.	T35731C3	T35731C2	T35731C1	T35731C0	T35731M0	T35731F0	

## SC 6.60mm Large Barrel (Cross Cut) Bit 6.60mm直筒平头交叉SC齿

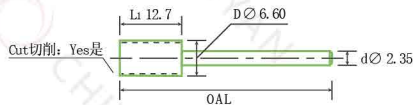

密度 Coarseness	Ultra Coarse 4XC	Triple Coarse 3XC	Double Coarse XXC	Extra Coarse XC	Coarse C	Medium M	Fine F	
订单编号 Order No.	T00432C4	T00432C3	T00432C2	T00432C1	T00432C0	T00432M0	T00432F0	

Carbide Bit  
钨钢磨头

**SC 6.60mm Large Barrel Smooth Top (Cross Cut) Bit 6.60mm直筒光头交叉SC齿**

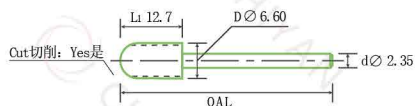

密度 Coarseness	Ultra Coarse 4XC	Triple Coarse 3XC	Double Coarse XXC	Extra Coarse XC	Coarse C	Medium M	Fine F
订单编号 Order No.	T07632C4	T07632C3	T07632C2	T07632C1	T07632C0	T07632M0	T07632F0

**SC 5.35mm Small Barrel (Cross Cut) Bit 5.35mm直筒平头交叉SC齿**

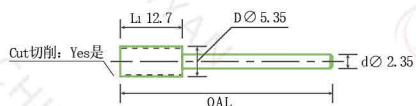

密度 Coarseness	Ultra Coarse 4XC	Triple Coarse 3XC	Double Coarse XXC	Extra Coarse XC	Coarse C	Medium M	Fine F
订单编号 Order No.	T00232C4	T00232C3	T00232C2	T00232C1	T00232C0	T00232M0	T00232F0

## 5.2mm 5 In 1 Cross Cut Bit 5.2mm五合一交叉齿

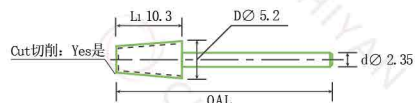

密度 Coarseness	Extra Coarse XC	Coarse C	Medium M	Fine F	Extra Fine XF
订单编号 Order No.	T35523C1	T35523C0	T35523M0	T35523F0	T35523F1

## Small Cone Bit 3.1mm锥形球头

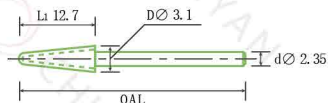

密度 Coarseness	Coarse C	Medium M	Fine F
订单编号 Order No.	C25204C0	C25204M0	C25204F0

## Safety Bit 5.2mm锥形球头

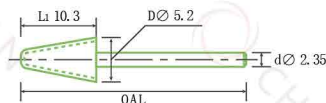

密度 Coarseness	Coarse C	Medium M	Fine F
订单编号 Order No.	T25404C0	T25404M0	T25404F0

**Cone Bit 4.0mm锥形球头**

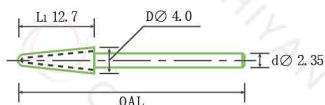

密度 Coarseness	Extra Coarse XC	Coarse C	Medium M	Fine F	Extra Fine XF
订单编号 Order No.	C25304C1	C25304C0	C25304M0	C25304F0	C25304F1

**Large Safety Bit 6.0mm锥形球头**

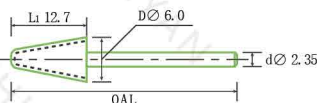

密度 Coarseness	Coarse C	Medium M	Fine F
订单编号 Order No.	T25604C0	T25604M0	T25604F0



## Volcano Bit 7.0mm锥形球头

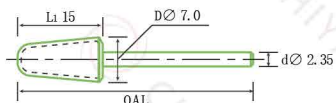

密度 Coarseness	Triple Coarse 3XC	Double Coarse XXC	Extra Coarse XC	Coarse C	Medium M	Fine F	Extra Fine XF
订单编号 Order No.	T25905C3	T25905C2	T25905C1	T25905C0	T25905M0	T25905F0	T25905F1

## Volcano Bit (2Way) 7.0mm锥形球头 (双向)

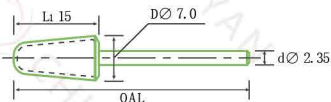

密度 Coarseness	Triple Coarse 3XC	Double Coarse XXC	Extra Coarse XC	Coarse C	Medium M	Fine F	Extra Fine XF
订单编号 Order No.	T25925C3	T25925C2	T25925C1	T25925C0	T25925M0	T25925F0	T25925F1

**Tornado Bit 7.0mm龙卷风**

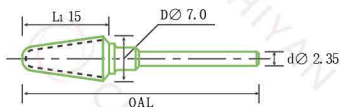

密度 Coarseness	Super Coarse 5XC	Ultra Coarse 4XC	Triple Coarse 3XC	Double Coarse XXC	Extra Coarse XC	Coarse C	Medium M	Fine F	
订单编号 Order No.	T20905C5	T20905C4	T20905C3	T20905C2	T20905C1	T20905C0	T20905M0	T20905F0	

**Tapered Barrel Bit 5.2mm锥形平头**

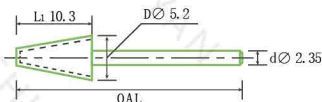

密度 Coarseness	Extra Coarse XC	Coarse C	Medium M	Fine F	
订单编号 Order No.	T30104C1	T30104C0	T30104M0	T30104F0	

**Large Tapered Barrel Bit 6.6mm锥形平头**

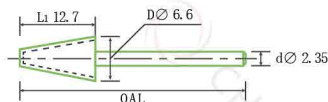

密度 Coarseness	Coarse C	Medium M	Fine F	Extra Fine XF	
订单编号 Order No.	T30524C0	T30524M0	T30524F0	T30524F1	

### Mini Cone bit 4.0mm小玉米

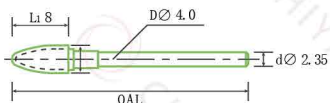

密度 Coarseness	Coarse C	Medium M	Fine F	Extra Fine XF
订单编号 Order No.	C69805C0	C69805M0	C69805F0	C69805F1

### Large Cone Bit 6.0mm大玉米

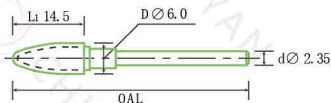

密度 Coarseness	Double Coarse XXC	Extra Coarse XC	Coarse C	Medium M	Fine F	Extra Fine XF
订单编号 Order No.	T69905C2	T69905C1	T69905C0	T69905M0	T69905F0	T69905F1



钨钢磨头  
Carbide Bit



**Oval Tornado Bit 6.0mm椭圆龙卷风**

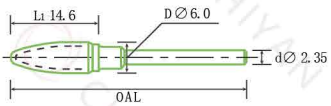

密度 Coarseness	Extra Coarse XC	Coarse C	Medium M	Fine F	Extra Fine XF
订单编号 Order No.	T60205C1	T60205C0	T60205M0	T60205F0	T60205F1



**Typhoon Bit 6.0mm台风形**

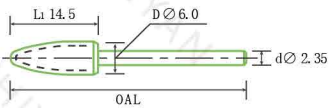

密度 Coarseness	Triple Coarse 3XC	Double Coarse XXC	Extra Coarse XC	Coarse C	Medium M	Fine F	Extra Fine XF
订单编号 Order No.	T60105C3	T60105C2	T60105C1	T60105C0	T60105M0	T60105F0	T60105F1

## Typhoon Bit (2Way) 6.0mm台风形 (双向)

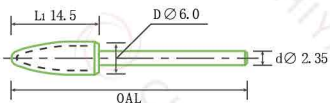

密度 Coarseness	Triple Coarse 3XC	Double Coarse XXC	Extra Coarse XC	Coarse C	Medium M	Fine F	Extra Fine XF
订单编号 Order No.	T60125C3	T60125C2	T60125C1	T60125C0	T60125M0	T60125F0	T60125F1

## Flame Bit 6.0mm火炬状

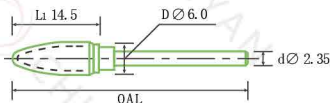

密度 Coarseness	Extra Coarse XC	Coarse C	Medium M	Fine F
订单编号 Order No.	T60004C1	T60004C0	T60004M0	T60004F0

## Big Flame Shape Bit-Pedicure 8.0mm火炬状 Big Rounded Top Bit-Pedicure 8.0mm直筒球头

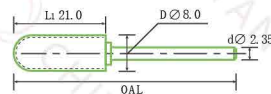
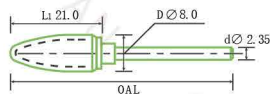

密度 Coarseness	Fine F	Coarse C
订单编号 Order No.	T62008F0	T09708C0



### Upgrade Flame Bit 6.0mm火炬状 (升级版)

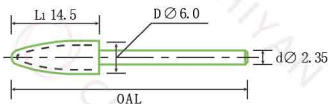

密度 Coarseness	Coarse C	Medium M	Fine F	Extra Fine XF
订单编号 Order No.	T60124C0	T60124M0	T60124F0	T60124F1



### 2-Week Backfill Bit 二周钻

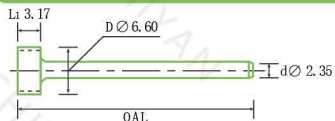

密度 Coarseness	Coarse C	Medium M	Fine F
订单编号 Order No.	T98924C0	T98924M0	T98924F0

### 4-Week Backfill Bit 四周钻

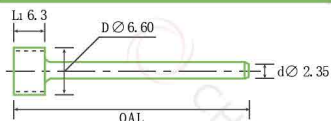

密度 Coarseness	Coarse C	Medium M	Fine F
订单编号 Order No.	T99024C0	T99024M0	T99024F0

### Tapered Backfill Bit 四周顺锥

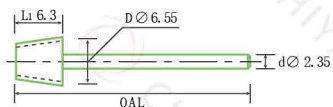

密度 Coarseness	Coarse C	Medium M	Fine F
订单编号 Order No.	T99204C0	T99204M0	T99204F0

### Inverted Backfill Bit 四周倒锥

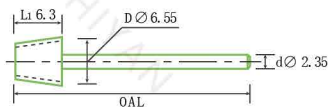

密度 Coarseness	Coarse C	Medium M	Fine F
订单编号 Order No.	T99104C0	T99104M0	T99104F0

### Sharp Point Bit 小锥形球头



密度 Coarseness	Coarse C	Medium M	Fine F
订单编号 Order No.	C20004C0	C20004M0	C20004F0

### Round bit 小直筒球头

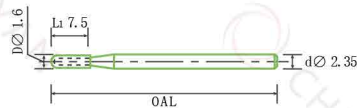

密度 Coarseness	Coarse C	Medium M	Fine F	Extra Fine XF
订单编号 Order No.	C09106C0	C09106M0	C09106F0	C09106F1

### Under Nail Cleaner Bit 针状平头

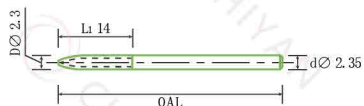

密度 Coarseness	Coarse C	Medium M	Fine F	Extra Fine XF
订单编号 Order No.	C95904C0	C95904M0	C95904F0	C95904F1

### Upgrade Round Bit 小直筒球头 (升级版)



密度 Coarseness	Medium M
订单编号 Order No.	C09128M0

### Ball Shape Bit-Pedicure 5.0mm球头(足部)



刃 径 Dmm	5.0
订单编号 Order No.	C80407M0

### Flame Shape Bit-Pedicure 火炬状(足部)

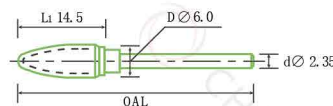

密度 Coarseness	Medium M
订单编号 Order No.	T68028M0

### Solid Carbide Polygon Bit 多边形磨头



形状 Shape	七边形 Septangle	八边形 Octagon
订单编号 Order No.	C93141C0	C93141M0

### Hexagon Bit 六边形

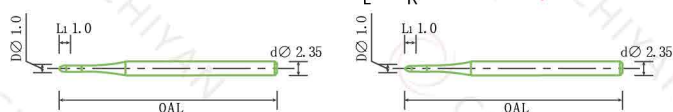

形状 Shape	六边形 Hexagon(Round)	六边形 Hexagon(Sharp)
订单编号 Order No.	C93041C1	C93141C1

### Solid Carbide Mini Polygon Bit 迷你多边形磨头

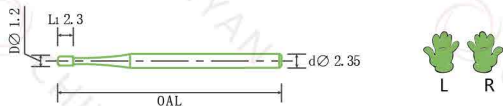

形状 Shape	迷你八边形 Mini Octagon
订单编号 Order No.	C93041M0

### Pear Shape Bit 梨形



形状 Shape	Extra Fine XF	Extra Fine XF
订单编号 Order No.	C97904F1	C97804F1

### Cuticle Clean Bit 角质清洁磨头



密度 Coarseness	Coarse C	Medium M	Fine F
订单编号 Order No.	C94922C0	C94922M0	C94922F0

### Pear Shape Bit 梨形

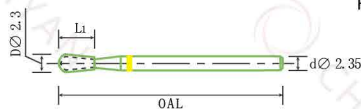

刃径 Dmm	2.3	
订单编号 Order No.	C97904F2	

### Remove Ornaments Bit 卸钻磨头



密度 Coarseness	Medium M
订单编号 Order No.	C20042M0

### Ball Shape Bit (Cross Cut) 球形 (交叉齿)



刃径 Dmm	2.3	2.7	3.0
订单编号 Order No.	C80004M0	C80104M0	C80204M0

### Ball Shape Bit (Plain Cut) 球形 (右旋齿)

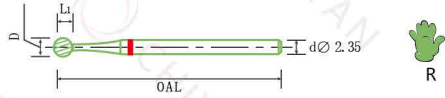

刃径 Dmm	2.3	3.0	2.7	3.0
订单编号 Order No.	C80001F0	C80201F0	C80101M0	C80201M0

### Nature Nail Buffer Bit 本甲刻磨磨头

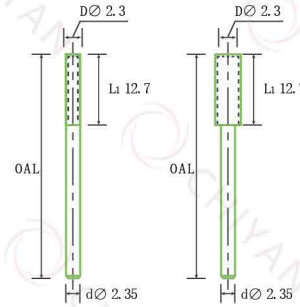

刃径 Dmm	2.3	5.35
订单编号 Order No.	C00109F1	T00209F1

### Hollow Cutter Bit-Pedicure 鸡眼刀 (不带齿)

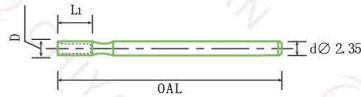

刃径 Dmm	1.8	2.3	2.7	3.0
订单编号 Order No.	S97090P0	S97190P0	S97290P0	S97390P0

### Hollow Cutter Toothed Bit-Pedicure 鸡眼刀 (带齿)

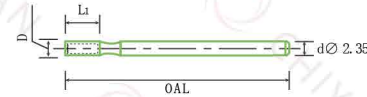

刃径 Dmm	1.8	2.3	2.7	3.0
订单编号 Order No.	S97090T0	S97190T0	S97290T0	S97390T0



### Conical Shape Bit (Cross Cut) 锥形 (交叉齿)

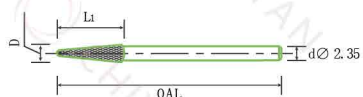

密度 Coarseness	Medium M	Medium M	
订单编号 Order No.	C5000328	C5000344	

### Spiral Cut 螺旋齿

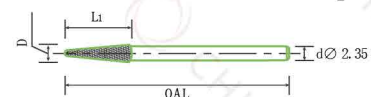

刃径 Dmm	4.0	
订单编号 Order No.	C5001406	

### Straight Edge With Spiral Cut 直刃螺旋齿

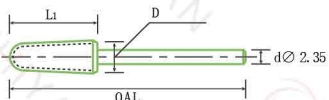

刃径 Dmm	2.3	4.5	4.0	6.0	7.0	7.0	6.0	4.0	3.0	
订单编号 Order No.	C5001201	C5001202	C5001203	C5001204	C5001205	C50A1205	C5001206	C5001207	C5000328	

# TOP 10 SELLER

## --- Carbide Bit



钨钢磨头  
Carbide Bit



陶瓷磨头

Ceramic Bit

# 陶瓷美甲磨头规格 Ceramic Bit Specifications

Coarseness: 齿密度		Ring 色圈	
	Ultra Coarse 四倍特粗齿	4XC	
	Triple Coarse 三倍特粗齿	3XC	
	Double Coarse 两倍特粗齿	XXC	
	Extra Coarse 超粗齿	XC	

	Coarse 粗齿	C	
	Medium 标准齿	M	
	Fine 细齿	F	

	Extra Fine 超细齿	XF	
	Double Fine 两倍特细齿	XXF	
	Triple Fine 三倍特细齿	3XF	

Flute Diameter (D) 刃径

Cut 切削: Yes是 No否

Color颜色:

White 白色	Black 黑色	Pink 粉色	Yellow 黄色	Blue 蓝色

For Left Hand  
左手

For Right Hand  
右手

For Left and Right Hand  
左右手

Shank Diameter 柄径:  
3/32" (2.35mm)  
1/8" (3.175mm)



**Large Barrel Bit 6.60mm直筒平头**

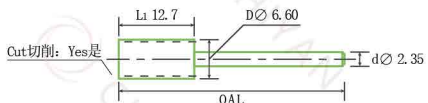

密度 Coarseness	Ultra Coarse 4XC	Triple Coarse 3XC	Double Coarse XXC	Extra Coarse XC	Coarse C	Medium M	Fine F	Extra Fine XF	Double Fine XXF	Triple Fine 3XF
订单编号 Order No.	Z00424C4	Z00424C3	Z00424C2	Z00424C1	Z00424C0	Z00424M0	Z00424F0	Z00424F1	Z00424F2	Z00424F3

**Large Barrel Bit (Chamfer) 6.60mm直筒平头 (倒角)**

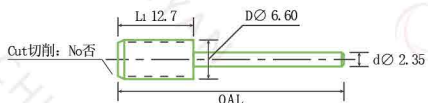

密度 Coarseness	Ultra Coarse 4XC	Triple Coarse 3XC	Double Coarse XXC	Extra Coarse XC	Coarse C	Medium M	Fine F	Extra Fine XF	Double Fine XXF	Triple Fine 3XF
订单编号 Order No.	Z01924C4	Z01924C3	Z01924C2	Z01924C1	Z01924C0	Z01924M0	Z01924F0	Z01924F1	Z01924F2	Z01924F3

## Crystal Large Barrel Bit (Corner Radius) 6.60mm带钻直筒平头 (圆角)

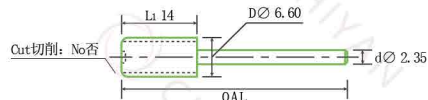

密度 Coarseness	Ultra Coarse 4XC	Triple Coarse 3XC	Double Coarse XXC	Extra Coarse XC	Coarse C	Medium M	Fine F	Extra Fine XF	Double Fine XXF
									
订单编号 Order No.	Z04624C4	Z04624C3	Z04624C2	Z04624C1	Z04624C0	Z04624M0	Z04624F0	Z04624F1	Z04624F2

## Crystal Large Barrel Bit (R Cut) 6.60mm带钻直筒平头 (R角)

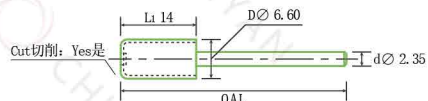

密度 Coarseness	Ultra Coarse 4XC	Triple Coarse 3XC	Double Coarse XXC	Extra Coarse XC	Coarse C	Medium M	Fine F	Extra Fine XF	Double Fine XXF
									
订单编号 Order No.	Z05524C4	Z05524C3	Z05524C2	Z05524C1	Z05524C0	Z05524M0	Z05524F0	Z05524F1	Z05524F2

### Large Barrel Smooth Top Bit 6.60mm直筒光头

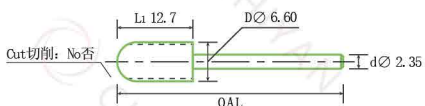

密度 Coarseness	Triple Coarse 3XC	Double Coarse XXC	Extra Coarse XC	Coarse C	Medium M	Fine F	Extra Fine XF	Double Fine XXF
订单编号 Order No.	Z07624C3	Z07624C2	Z07624C1	Z07624C0	Z07624M0	Z07624F0	Z07624F1	Z07624F2

### Large Rounded Top Bit 6.60mm直筒球头

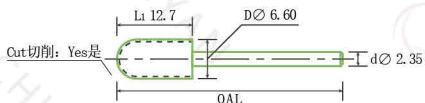

密度 Coarseness	Triple Coarse 3XC	Double Coarse XXC	Extra Coarse XC	Coarse C	Medium M	Fine F	Extra Fine XF
订单编号 Order No.	Z09624C3	Z09624C2	Z09624C1	Z09624C0	Z09624M0	Z09624F0	Z09624F1

### Small Barrel Bit 6.0mm直筒平头

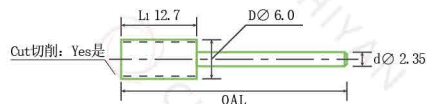

密度 Coarseness	Ultra Coarse 4XC	Triple Coarse 3XC	Double Coarse XXC	Extra Coarse XC	Coarse C	Medium M	Fine F	Extra Fine XF	Double Fine XXF
订单编号 Order No.	Z00224C4	Z00224C3	Z00224C2	Z00224C1	Z00224C0	Z00224M0	Z00224F0	Z00224F1	Z00224F2

### Small Barrel Bit (Chamfer) 6.0mm直筒平头 (倒角)

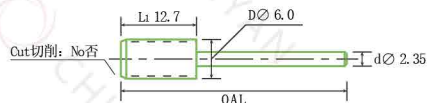

密度 Coarseness	Ultra Coarse 4XC	Triple Coarse 3XC	Double Coarse XXC	Extra Coarse XC	Coarse C	Medium M	Fine F	Extra Fine XF	Double Fine XXF
订单编号 Order No.	Z01724C4	Z01724C3	Z01724C2	Z01724C1	Z01724C0	Z01724M0	Z01724F0	Z01724F1	Z01724F2



**Small Barrel Smooth Top Bit 6.0mm直筒光头**

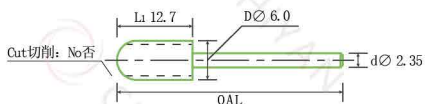

密度 Coarseness	Triple Coarse 3XC	Double Coarse XXC	Extra Coarse XC	Coarse C	Medium M	Fine F	Extra Fine XF	Double Fine XXF
订单编号 Order No.	Z07324C3	Z07324C2	Z07324C1	Z07324C0	Z07324M0	Z07324F0	Z07324F1	Z07324F2

**Small Rounded Top Bit 6.0mm直筒球头**

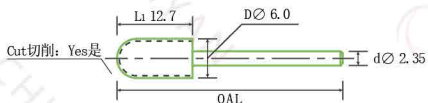

密度 Coarseness	Triple Coarse 3XC	Double Coarse XXC	Extra Coarse XC	Coarse C	Medium M	Fine F	Extra Fine XF
订单编号 Order No.	Z09324C3	Z09324C2	Z09324C1	Z09324C0	Z09324M0	Z09324F0	Z09324F1

### 3 In 1 三合一

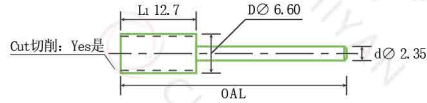

密度 Coarseness	Triple Coarse 3XC	Double Coarse XXC	Extra Coarse XC	Coarse C	Medium M	Fine F	Extra Fine XF	Double Fine XXF
订单编号 Order No.	Z03425C3	Z03425C2	Z03425C1	Z03425C0	Z03425M0	Z03425F0	Z03425F1	Z03425F2

### 5 In 1 五合一

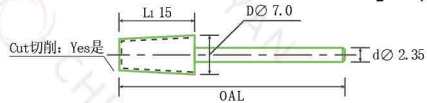

密度 Coarseness	Triple Coarse 3XC	Double Coarse XXC	Extra Coarse XC	Coarse C	Medium M	Fine F	Extra Fine XF	Double Fine XXF
订单编号 Order No.	Z35725C3	Z35725C2	Z35725C1	Z35725C0	Z35725M0	Z35725F0	Z35725F1	Z35725F2

**Small Cone Bit 3.1mm锥形球头**

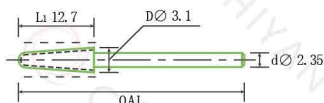

密度 Coarseness	Coarse C	Medium M
订单编号 Order No.	Y25204C0	Y25204M0

**Cone Bit 4.0mm锥形球头**

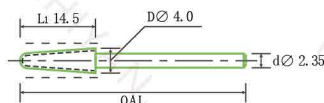

密度 Coarseness	Extra Coarse XC	Coarse C	Medium M	Fine F
订单编号 Order No.	Z25324C1	Z25324C0	Z25324M0	Z25324F0

**Big Cone Bit 6.0mm锥形球头**

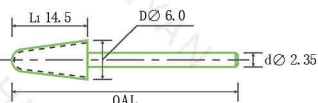

密度 Coarseness	Extra Coarse XC	Coarse C	Medium M	Fine F
订单编号 Order No.	Z25724C1	Z25724C0	Z25724M0	Z25724F0



## Large Tapered Barrel Bit 6.6mm锥形平头

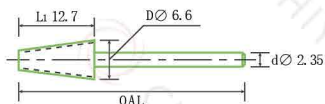

密度 Coarseness	Double Coarse XXC	Extra Coarse XC	Coarse C	Medium M	Fine F	Extra Fine XF
订单编号 Order No.	Z30524C2	Z30524C1	Z30524C0	Z30524M0	Z30524F0	Z30524F1

## Volcano Bit 7.0mm火山形

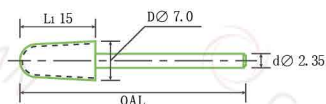

密度 Coarseness	Extra Coarse XC	Coarse C	Medium M	Fine F
订单编号 Order No.	Z25905C1	Z25905C0	Z25905M0	Z25905F0

## Volcano Bit With Step 7.0mm台阶火山形

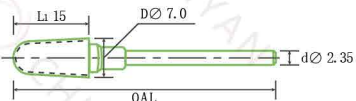

密度 Coarseness	Triple Coarse 3XC-8	Double Coarse XXC-10	Extra Coarse XC-12	Coarse C-16	Medium M-24	Fine F-36	Extra Fine XF-40
订单编号 Order No.	Z6100953	Z6100954	Z6100955	Z6100956	Z6100957	Z6100958	Z6100959

**Volcano Bit (2 Way) 7.0mm锥形球头 (双向)**

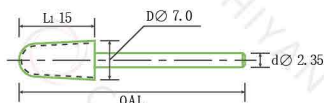

密度 Coarseness	Triple Coarse 3XC	Double Coarse XXC	Extra Coarse XC	Coarse C	Medium M	Fine F	Extra Fine XF	Double Fine XXF
订单编号 Order No.	Z25925C3	Z25925C2	Z25925C1	Z25925C0	Z25925M0	Z25925F0	Z25925F1	Z25925F2

**Typhoon Bit 6.0mm台风形**

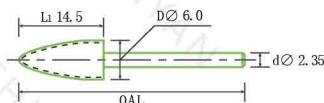

密度 Coarseness	Extra Coarse XC	Coarse C	Medium M	Fine F
订单编号 Order No.	Z60105C1	Z60105C0	Z60105M0	Z60105F0

**Flame Bit (Left hand) 6.0mm火炬状 (左手)**

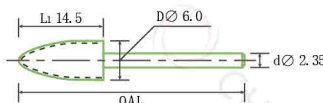

密度 Coarseness	Coarse C	Medium M	Fine F
订单编号 Order No.	Z60113C0	Z60113M0	Z60113F0

## Typhoon Bit (2 Way) 6.0mm台风形 (双向)

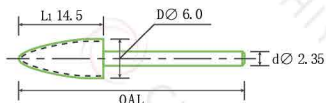

密度 Coarseness	Double Coarse XXC	Extra Coarse XC	Coarse C	Medium M	Fine F	Extra Fine XF	Double Fine XXF
订单编号 Order No.	Z60125C2	Z60125C1	Z60125C0	Z60125M0	Z60125F0	Z60125F1	Z60125F2

## Flame Bit 6.0mm火炬状

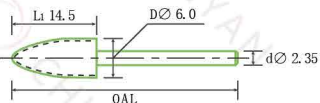

密度 Coarseness	Extra Coarse XC	Coarse C	Medium M	Fine F	Extra Fine XF	Double Fine XXF	Triple Fine 3XF
订单编号 Order No.	Z60104C1	Z60104C0	Z60104M0	Z60104F0	Z60104F1	Z60104F2	Z60104F3

**Upgrade Flame Bit 6.0mm火炬状 (升级版)**

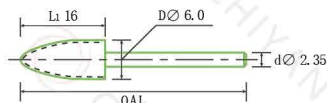

密度 Coarseness	Double Coarse XXC	Extra Coarse XC	Coarse C	Medium M	Fine F	Extra Fine XF	Double Fine XXF
订单编号 Order No.	Z60424C2	Z60424C1	Z60424C0	Z60424M0	Z60424F0	Z60424F1	Z60424F2

**Long Flame Bit 6.0mm长刃火炬状**

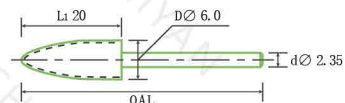

密度 Coarseness	Coarse C	Medium M	Fine F
订单编号 Order No.	Z60704C0	Z60704M0	Z60704F0

**Upgrade Round Bit 小直筒球头 (升级版)**

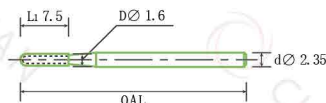

密度 Coarseness	Medium M
订单编号 Order No.	Y09128M0

## Round Bit 小直筒球头

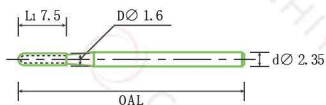

密度 Coarseness	Coarse C	Medium M	Fine F	Extra Fine XF	Double Fine XXF
订单编号 Order No.	T01724C0	T01724M0	T01724F0	T01724F1	T01724F2

## Under Nail Cleaner Bit 针状平头

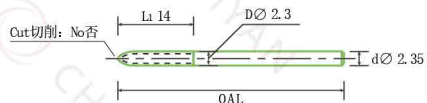

密度 Coarseness	Coarse C	Medium M	Fine F	Extra Fine XF
订单编号 Order No.	Y95904C0	Y95904M0	Y95904F0	Y95904F1

## Solid Carbide Mini Polygon Bit 迷你多边形磨头

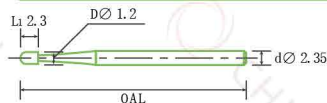

形状 Shape	迷你八边形 Mini Octagon
订单编号 Order No.	Y93041M0

陶瓷磨头  
Ceramic Bit



**Cuticle Clean Bit 角质清洁磨头**

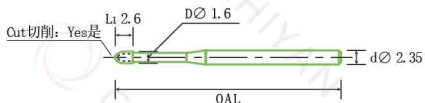

密度 Coarseness	Extra Coarse XC	Coarse C	Medium M	Fine F
订单编号 Order No.	Y94922C1	Y94922C0	Y94922M0	Y94922F0



**Ball Shape Bit (Cross Cut) 球形 (交叉齿)**

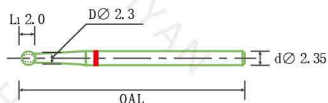

刀 径 Dmm	2.3	2.3	2.3	3.0	3.0
订单编号 Order No.	Y80022C0	Y80022M0	Y80022F0	Y80222C0	Y80222M0



### Conical Shape Bit 锥形

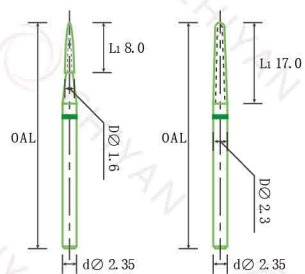

刃径 Dmm	2.3	1.2
订单编号 Order No.	Y20004C1	Y20107C1

### Flame Shape Bit-Pedicure 6.0mm火炬状(足部)

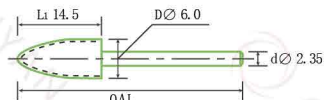

密度 Coarseness	Coarse C	Medium M	Fine F
订单编号 Order No.	Z60108C0	Z60108M0	Z60108F0

### Cylindrical Shape Bit 直筒球头

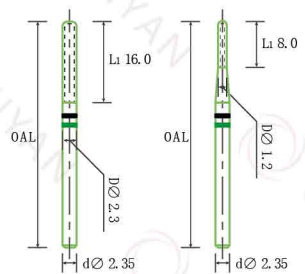

刃径 Dmm	2.3	1.2
订单编号 Order No.	Y09204C2	Y09004C2

### Big Rounded Top Bit-Pedicure 8.0mm直筒球头

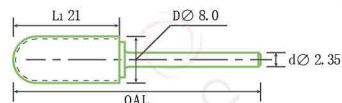

密度 Coarseness	Coarse C	Medium M	
订单编号 Order No.	Z60108C0	Z60108M0	

**Nature Nail Buffer Bit 本甲刻磨磨头**

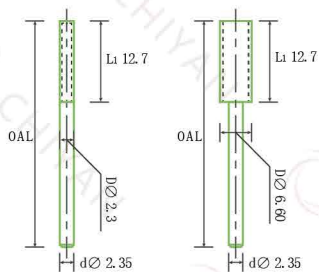

刃 径 Dmm	2.3	6.6
订单编号 Order No.	Y00109F1	Z00409F1

**Bullet Shape (Cross Cut) 子弹形 (交叉齿)**

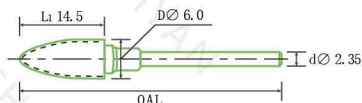

密度 Coarseness	Double Coarse XXC	Extra Coarse XC	Coarse C	Medium M	Fine F	Extra Fine XF	Double Fine XXF
订单编号 Order No.	Z6400201	Z6400301	Z6400401	Z6400501	Z6400601	Z6400701	Z6400801

## Bullet Shape (Cross Cut) 子弹形 (交叉齿)

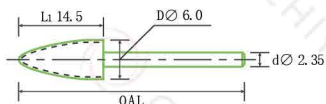

密度 Coarseness	Double Coarse XXC	Extra Coarse XC	Coarse C	Medium M	Fine F	Extra Fine XF	Double Fine XXF
订单编号 Order No.	Z6410201	Z6410301	Z6410401	Z6410501	Z6410601	Z6410701	Z6410801

## Bullet Shape (Spiral Cut) 子弹形 (直刃螺旋齿)

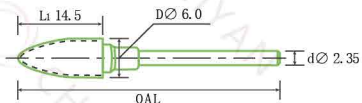

密度 Coarseness	Coarse C	Medium M	Fine F
订单编号 Order No.	Z6402401	Z6402501	Z6402601

## Bullet Shape (Left Hand) 子弹形 (左手齿)

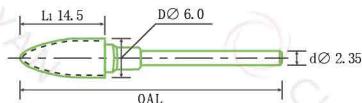

密度 Coarseness	Coarse C	Medium M	Fine F
订单编号 Order No.	Z6406401	Z6406501	Z6406601

**Conical Shape (Cross Cut) 锥形 (交叉齿)**

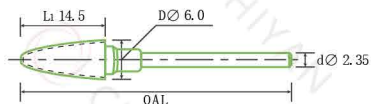

密度 Coarseness	Double Coarse XXC	Extra Coarse XC	Coarse C	Medium M	Fine F	Extra Fine XF	Double Fine XXF
订单编号 Order No.	Z6400202	Z6400302	Z6400402	Z6400502	Z6400602	Z6400702	Z6400802

**Conical Shape (Cross Cut) 锥形 (交叉齿)**

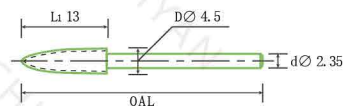

密度 Coarseness	Extra Coarse XC	Coarse C	Medium M	Fine F
订单编号 Order No.	Z6400305	Z6400405	Z6400505	Z6400605

**Conical Shape (Cross Cut) 锥形 (交叉齿)**

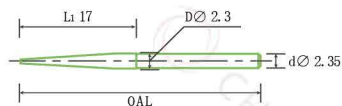

密度 Coarseness	Double Coarse XXC	Extra Coarse XC
订单编号 Order No.	Z6300207	Z6300312

### Ball Shape (Cross Cut) 球形 (交叉齿)

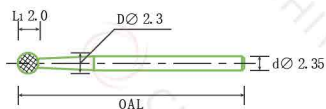

密度 Coarseness	Extra Coarse XC	Medium M
订单编号 Order No.	Z6300315	Z6300504

### Cylindrical (Cross Cut) 直筒球头 (交叉齿)

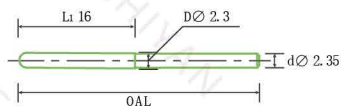

密度 Coarseness	Double Coarse XXC	Double Coarse XXC
订单编号 Order No.	Z6300206	Z6300211

### End Cut (Cross Cut) 直筒端齿 (交叉齿)



密度 Coarseness	Medium M	Fine F
订单编号 Order No.	Z6400503	Z6400603

### Ball Shape Bit-Pedicure 球形 (足部)



刃径 Dmm	3.0	4.0	5.0	6.0	7.0	8.0
订单编号 Order No.	Y80207M0	Z85107M0	Z85207M0	Z85307M0	Z85407M0	Z85507M0

# Ceramic Bit

★ ★ ★ TOP 10 Seller



- ① Large Barrel Bit
- ② Flame Bit
- ③ Large Barrel Smooth Bit
- ④ Bullet Bit (Cross Cut)
- ⑤ Under Nail Cleaner Bit
- ⑥ Small Rounded Top Bit
- ⑦ Flame Bit
- ⑧ Small Cone Bit (3.1mm)
- ⑨ Small Barrel Smooth Top Bit
- ⑩ Cluticle Clean Bit



金刚石磨头

Diamond Burs



金刚石美甲磨头规格  
Diamond Burs Specifications



## Diamond Burs 金刚石磨头

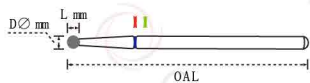

粒度 / 尺寸 Grit / Size (mm)	F 1.0*1.0	M 1.5*1.5	F 1.8*1.6	M 1.8*1.7	C 1.8*1.8	C 2.0*1.8	F 2.0*2.0	M 2.3*2.1	F 2.3*2.2	M 2.5*2.3
订单编号 Order No.	DD1010	DD1515	DD1816	DD1817	DD1818	DD2018	DD2020	DD2321	DD2322	DD2524

## Diamond Burs 金刚石磨头

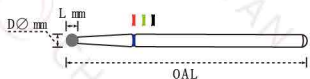

粒度 / 尺寸 Grit / Size (mm)	F 2.6*2.6	C 3.0*2.8	M 3.5*3.1	XC 3.6*4.0	F 4.2*3.6	C 4.3*3.7	M 5.0*4.7	C 5.3*4.8	M 6.0*5.7
订单编号 Order No.	DD2626	DD3028	DD3531	DD3640	DD4236	DD4337	DD5047	DD5348	DD6057

**Diamond Burs 金刚石磨头**

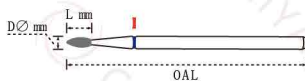

粒度 / 尺寸 Grit / Size (mm)	M 1.8*3.0	M 1.3*3.5	F 2.0*3.5	M 1.5*3.7	M 2.3*5.0	F 2.2*5.4	F 2.8*7.5
订单编号 Order No.	DD1830	DD1335	DD2035	DD1537	DD2350	DD2351	DD2875

**Diamond Burs 金刚石磨头**

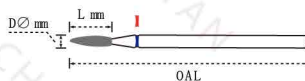

粒度 / 尺寸 Grit / Size (mm)	M 1.9*6.6	M 1.8*7.0	M 2.0*7.4	M 2.3*7.0	M 1.8*8.6	F 2.0*8.0	M 2.0*8.1	M 2.4*9.0	M 2.3*9.5	F 1.8*8.6
订单编号 Order No.	DD1966	DD1870	DD1970	DD2370	DD1780	DD2080	DD2081	DD2490	DD2395	DD1886

## Diamond Burs 金刚石磨头

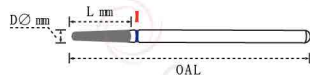

粒度 / 尺寸 Grit / Size (mm)	M 2.0*8.5	M 2.0*10	F 2.3*10	F 3.0*15	F 3.0*12
订单编号 Order No.	DD2085	DD2010	DD2310	DD3015	DD3012

## Diamond Burs 金刚石磨头

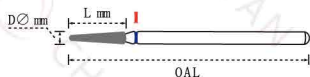

粒度 / 尺寸 Grit / Size (mm)	M 1.6*10	M 1.8*10	M 2.8*7.0	M 1.5*7.7	F 1.8*10	M 1.8*10	F 2.5*16.1
订单编号 Order No.	DD1610	DD1812	DD2870	DD1577	DD1810	DD1811	DD2617

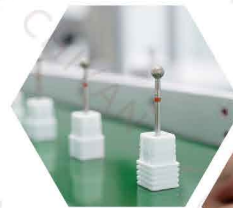

金刚石磨头  
Diamond Burs

Diamond Burs 金刚石磨头

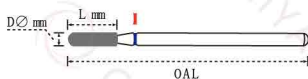

粒度 / 尺寸 Grit / Size (mm)	M 3.0*1.9	F 3.0*2.0	F 3.0*2.9	M 3.1*9.3	F 2.9*10.3	F 3.4*16	F 3.5*10	M 3.5*16	M 3.6*10	M 4.1*7.7
订单编号 Order No.	DD3019	DD3020	DD3029	DD3110	DD3111	DD3416	DD3510	DD3516	DD3610	DD4070

Diamond Burs 金刚石磨头

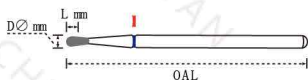

粒度 / 尺寸 Grit / Size (mm)	M 1.5*8.5	M 2.0*4.0	M 2.0*5.0	M 2.0*10	M 2.0*10	M 3.0*10	F 4.0*12
订单编号 Order No.	DD0108	DD0204	DD0205	DD0210	DD0211	DD0310	DD0412

### Diamond Burs 金刚石磨头

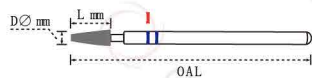

粒度 / 尺寸 Grit / Size (mm)	M 1.0*7.0	M 3.0*7.0	M 3.0*7.0	M 4.0*7.0	M 4.0*7.0	M 4.0*12	M 1.5*8.3	F 1.4*8.3
								
订单编号 Order No.	DD0110	DD0307	DD0308	DD0406	DD0407	DD0413	DD0414	DD0415

### Diamond Burs 金刚石磨头

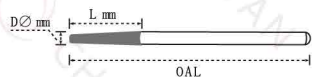

粒度 / 尺寸 Grit / Size (mm)	M 1.0*7.0	M 2.3*10.6	M 3.0*10	M 4.0*8.0	M 5.2*9.6	M 5.1*9.1
						
订单编号 Order No.	DD0105	DD0212	DD0311	DD0408	DD0508	DD0509



**Diamond Burs 金刚石磨头**



粒度 / 尺寸 Grit / Size (mm)	M 3.2*6.5	M 2.0*7.6	M 5.0*10	M 4.6*8.7	M 8.0*15	M 9.7*8.5	M 6.5*13	M 6.5*13	M 6.5*13	M 4.0*12	M 6.5*13
订单编号 Order No.	DD3265	DD2076	DD0510	DD0511	DD0815	DD0101	DD0102	DD0103	DD0104	DD0106	DD0107

**Diamond Burs 金刚石磨头**

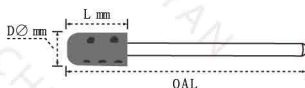

粒度 / 尺寸 Grit / Size (mm)	M 10.7*17.4	M 9.9*15.6	M 8.9*20.9	M 13.6*22.6	M 10*17.8
订单编号 Order No.	DD0001	DD0002	DD0003	DD0004	DD0005



### Diamond Burs 金刚石车针

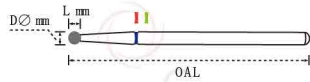

粒度 / 尺寸 Grit / Size (mm)	M 1.0*0.7	M 1.4*1.1	F 1.8*1.4	M 1.8*1.4	C 1.8*1.4	M 2.3*1.9	C 2.3*1.9
							
订单编号 Order No.	DD2013	DD2023	DD2034	DD2033	DD2032	DD2043	DD2042

### Diamond Burs 金刚石车针

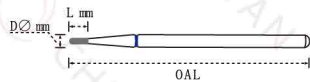

粒度 / 尺寸 Grit / Size (mm)	M 0.8*3.0	M 1.0*3.5	M 1.4*3.5	M 2.0*3.5	M 2.5*3.5	M 3.5*3.5
						
订单编号 Order No.	DD2053	DD2063	DD2073	DD2083	DD2093	DD2103





**Diamond Burs 金刚石车针**

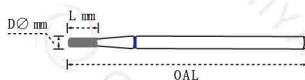

粒度 / 尺寸 Grit / Size (mm)	M 1.2*6.0	M 1.6*6.0	M 2.30*6.0	M 3.0*6.0	M 4.0*6.0	M 1.2*12	M 1.6*12	M 2.3*12	M 3.0*12	M 4.0*12
订单编号 Order No.	DD2113	DD2123	DD2133	DD2143	DD2153	DD2163	DD2173	DD2183	DD2193	DD2203

**Diamond Burs 金刚石车针**

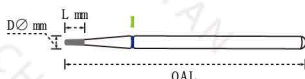

粒度 / 尺寸 Grit / Size (mm)	M 1.0*4.0	M 1.4*4.0	M 1.8*4.0	M 2.5*4.0	C 4.0*8.0	M 4.0*8.0	C 4.0*12	M 4.0*12
订单编号 Order No.	DD2213	DD2223	DD2233	DD2243	DD2352	DD2353	DD2392	DD2393

## Diamond Burs 金刚石车针

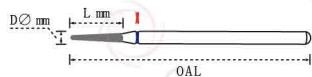

粒度 / 尺寸 Grit / Size (mm)	M 1.2*10	M 1.6*10	F 1.6*10	M 2.1*10	M 2.5*10	F 2.5*10	M 3.0*10	M 3.5*10	M 4.0*10
订单编号 Order No.	DD2253	DD2263	DD2264	DD2273	DD2283	DD2284	DD2293	DD2303	DD2313

## Diamond Burs 金刚石车针

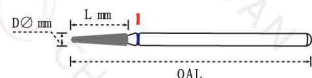

粒度 / 尺寸 Grit / Size (mm)	M 1.2*8.0	M 1.8*8.0	F 1.8*8.0	M 2.5*8.0	M 1.2*12	M 1.8*12	F 1.8*12	M 2.5*12
订单编号 Order No.	DD2323	DD2333	DD2334	DD2343	DD2363	DD2373	DD2374	DD2383

**Diamond Burs 金刚石车针**

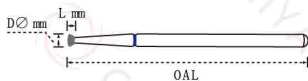

粒度 / 尺寸 Grit / Size (mm)	M 2.0*1.0	M 3.0*1.3	M 4.0*1.5	M 5.0*2.0	M 3.0*1.2	M 4.0*1.2	M 5.0*1.2	M 3.0*2.0	M 4.0*2.0	M 5.0*2.0
订单编号 Order No.	DD2403	DD2413	DD2423	DD2433	DD2533	DD2543	DD2553	DD2563	DD2573	DD2583

**Diamond Burs 金刚石车针**

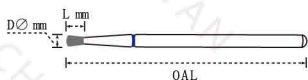

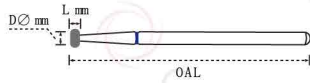

粒度 / 尺寸 Grit / Size (mm)	M 1.2*1.4	M 1.6*1.4	M 2.1*2.2	M 2.5*2.4	M 1.6*4.0	M 2.1*5.0	M 2.5*6.0	M 1.2*4.0	M 2.5*8.0
订单编号 Order No.	DD2443	DD2453	DD2463	DD2473	DD2483	DD2493	DD2503	DD2513	DD2523

**Diamond Burs 金刚石车针**

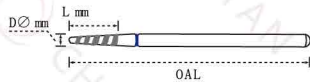
粒度 / 尺寸 Grit / Size (mm)	M 3.0*1.8	M 4.0*1.8	M 5.0*1.8	M 3.0*1.0	M 4.0*1.0	M 5.0*1.0	M 2.8*14	M 4.8*12
								
订单编号 Order No.	DD2593	DD2603	DD2613	DD2623	DD2633	DD2643	DD2653	DD2663

**Diamond Burs 金刚石车针**

粒度 / 尺寸 Grit / Size (mm)	F 2.1*10	M 2.1*10	M 2.3*12	F 2.3*12	M 2.4*14	F 2.4*14	M 2.3*5.8	M 1.6*9.8	M 2.4*11	F 2.3*10
										
订单编号 Order No.	199-021 LxR	199-023 LxB	243-021 LxB	243-021 LxR	243-023 LxB	243-023 LxR	257-021 LxB	263-016 LxB	263-023 LxB	263-023 LxR

**Diamond Burs 金刚石车针**

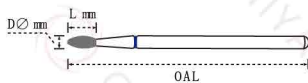

粒度 / 尺寸 Grit / Size (mm)	M 4.0*8.0	M 1.6*3.8	M 1.8*4.2	M 2.1*5.5	M 5.0*12	M 1.6*3.8	M 2.3*5.0	M 2.5*6.0	M 2.1*6.0	M 1.8*10
订单编号 Order No.	DD2043D	DD2063D	DD2073D	DD2083D	DD2093D	DD2103D	DD2113D	DD2123D	DD2133D	DD2753

**Diamond Burs 金刚石车针**

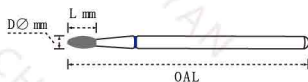

粒度 / 尺寸 Grit / Size (mm)	M 1.2*1.0	M 1.8*8.0	M 2.3*8.0	M 2.5*8.0	M 2.2*5.0	M 1.6*10	M 3.0*3.0	M 1.6*8.0	M 2.1*8.0	M 2.8*6.0
订单编号 Order No.	DD2833	DD2843	DD2853	DD2863	DD2913	DD2923	DD2943	DD2963	DD2973	DD2983

## Diamond Burs 金刚石车针

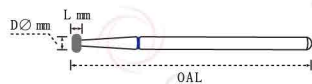

粒度 / 尺寸 Grit / Size (mm)	M 2.0*7.4	M 2.0*8.5	F 1.8*7.6	M 6.0*5.7	M 7.0*6.9
订单编号 Order No.	DD1970D	DD2085D	DD2154D	DD6057D	DD7068D

**10.0mm Diamond Bit-Pedicure** 10.0mm金刚砂 (足部)



密度 Coarseness	Coarse C	Medium M	Fine F
订单编号 Order No.	A029011	A029012	A029013

**13.0mm Diamond Bit-Pedicure** 13.0mm金刚砂 (足部)

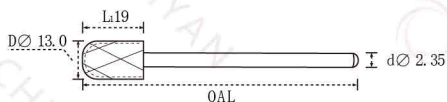

密度 Coarseness	Coarse C	Medium M	Fine F
订单编号 Order No.	A029001	A029002	A029003

CHIYAN

# Diamond Bur

★ ★ ★ TOP 10 Seller

①	②	③	④	⑤	⑥	⑦	⑧	⑨	⑩
DD	DD	DD	DD	DD	DD	DD	DD	DD	DD
1010	2322	3640	2875	2370	1886	2076	2513	1610	1830



Diamond Burs  
金刚石磨头





砂卷

Sanding Band

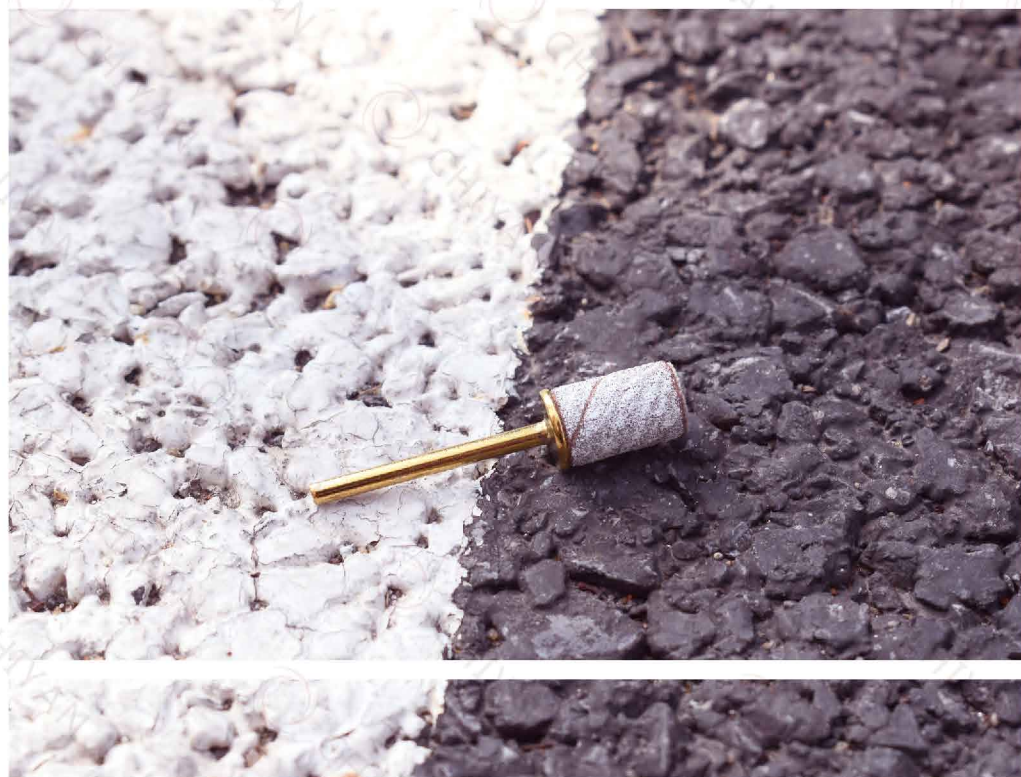

砂圈规格  
Sanding Band Specifications



**Material:**

Aluminum Oxide  
Japan NCA  
Silicon Carbide  
USA Norton



**White Sanding Band**

粒度 / 尺寸 Grit / Size (mm)	#80 6.35*12.7	#100 6.35*12.7	#120 6.35*12.7	#150 6.35*12.7	#180 6.35*12.7	#240 6.35*12.7
材质 Material Aluminum Oxide Japan NCA						
订单编号 Order No.	SD6351271	SD6351272	SD6351273	SD6351274	SD6351275	SD6351276

**Brown Sanding Band**

粒度 / 尺寸 Grit / Size (mm)	#80 6.35*12.7	#150 6.35*12.7	#240 6.35*12.7
材质 Material Aluminum Oxide			
订单编号 Order No.	SD6351277	SD6351278	SD6351279

**Black Sanding Band**

粒度 / 尺寸 Grit / Size (mm)	#80 6.35*12.7	#100 6.35*12.7	#120 6.35*12.7	#150 6.35*12.7	#180 6.35*12.7	#240 6.35*12.7
材质 Material Silicon Carbide Japan NCA						
订单编号 Order No.	SD6351280	SD6351281	SD6351282	SD6351283	SD6351284	SD6351285

**Green Sanding Band**

粒度 / 尺寸 Grit / Size (mm)	#80 6.35*12.7	#120 6.35*12.7	#150 6.35*12.7	#180 6.35*12.7
材质 Material Aluminum Oxide USA Norton				
订单编号 Order No.	SD6351286	SD6351287	SD6351288	SD6351289

CHIYAN

# Sanding Band

#80

#100

#120

#150

#180

#240



#180



#180



#180



#180



professional  
manicure & pedicure tools

CHIYAN

砂圈  
Sanding Band

# White Zebra Sanding bands

Material: Aluminum Oxide & Japan NCA

Color: White

Size: 6.35x12.7mm

Grit: #80/#100/#120/#150/#180/#240



## Advantage:

- Imported raw materials from Japan
- Non-toxic environmental protection transparent adhesive
- Excellent Heat Dissipation
- No clogging

# Brown Sanding Bands

Material: Aluminum Oxide

Color: Brown

Size: 6.35x12.7mm

Grit: #80/#150/#240



## Advantage:

- Domestic alumina material
- Low price and high cost performance



# Black Sanding bands

Material: Silicon Oxide & Japan NCA

Color: Black

Size: 6.35x12.7mm

Grit: #80/#100/#120/#150/#180/#240



## Advantage:

- High cost performance
- Imported raw materials from Japan
- Non-toxic environmental protection transparent adhesive
- Excellent Heat Dissipation
- No clogging

# Green sanding band

Material: Aluminum Oxide & USA Norton

Color: Green

Size: 6.35x12.7mm

Grit: #80/#120/#150/#180



## Advantage:

- It has high grinding force to prevent blockage
- It is stable and does not easily contaminate nails
- It is soft and fits the nails. Easy to operate
- Imported alumina material





## CHIYAN sanding band main advantages

1. Accurate Size (6.35mm\*12.7mm&6.5mm\*12.7mm) .
2. Sanding Surface is smooth. The glue is equally distributed. No extra glue spilled. No opening.
3. The cut is smooth and has no burrs. It is easy to polish the edges of the nails and easy to handle.
4. Two-component glue, firmly bonded.
5. Non-toxic, eco-friendly, transparent glue.
6. Optional grit from coarse to fine: 40#, 60#, 80#, 100#, 120#, 150#, 180#, 240#, 320#, 400#
7. High quality imported abrasive cloth material.
8. The abrasive material could be customized (MOQ 1000 meters).
9. Provide OEM&ODM.
10. 200,000pcs daily output assures a fast delivery.
11. Free Samples. Support product return.
12. Our workers have 15 years of production experience. We have a good control of the products quality.
13. Provide free package designing and technical assistance.
14. Defect Rate is lower than 1%.



砂帽

Sanding Cap

### Sanding Cap 砂帽

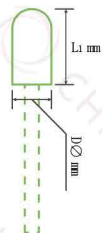

粒度 / 尺寸 Grit / Size (mm)	C 5*11	C 7*13	C 10*15	C 13*19	C 16*25
材质 Material Brown Fused Alumina					
订单编号 Order No.	CS0001	CS0002	CS0003	CS0004	CS0005

### Sanding Cap 砂帽

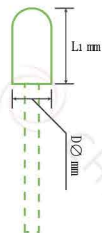

粒度 / 尺寸 Grit / Size (mm)	M 5*11	M 7*13	M 10*15	M 13*19	M 16*25
材质 Material Brown Fused Alumina					
订单编号 Order No.	CS0006	CS0007	CS0008	CS0009	CS0010

### Sanding Cap 砂帽

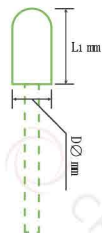

粒度 / 尺寸 Grit / Size (mm)	F 5*11	F 7*13	F 10*15	F 13*19	F 16*25
材质 Material Brown Fused Alumina					
订单编号 Order No.	CS0011	CS0012	CS0013	CS0014	CS0015

### Sanding Cap 砂帽

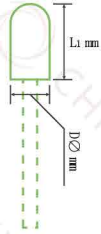

粒度 / 尺寸 Grit / Size (mm)	C 5*11	C 7*13	C 10*15	C 13*19	C 16*25
材质 Material Pink Fused Alumina					
订单编号 Order No.	CS0016	CS0017	CS0018	CS0019	CS0020

### Sanding Cap 砂帽

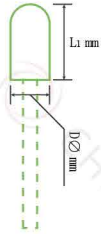

粒度 / 尺寸 Grit / Size (mm)	M 5*11	M 7*13	M 10*15	M 13*19	M 16*25
材质 Material Pink Fused Alumina					
订单编号 Order No.	CS0021	CS0022	CS0023	CS0024	CS0025

### Sanding Cap 砂帽

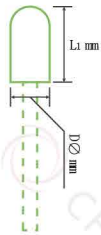

粒度 / 尺寸 Grit / Size (mm)	F 5*11	F 7*13	F 10*15	F 13*19	F 16*25
材质 Material Pink Fused Alumina					
订单编号 Order No.	CS0026	CS0027	CS0028	CS0029	CS0030

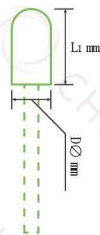
**Sanding Cap 砂帽**

粒度 / 尺寸 Grit / Size (mm)	C 5*11	C 7*13	C 10*15	C 13*19	C 16*25
材质 Material Green Silicon Carbide					
订单编号 Order No.	CS0031	CS0032	CS0033	CS0034	CS0035

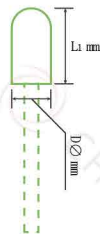
**Sanding Cap 砂帽**

粒度 / 尺寸 Grit / Size (mm)	M 5*11	M 7*13	M 10*15	M 13*19	M 16*25
材质 Material Green Silicon Carbide					
订单编号 Order No.	CS0036	CS0037	CS0038	CS0039	CS0040

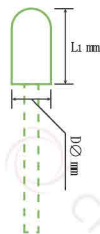
**Sanding Cap 砂帽**

粒度 / 尺寸 Grit / Size (mm)	F 5*11	F 7*13	F 10*15	F 13*19	F 16*25
材质 Material Green Silicon Carbide					
订单编号 Order No.	CS0041	CS0042	CS0043	CS0044	CS0045

# CHIYAN sanding cap main advantages



## Lining



## Chiyan:PA (Grade A Material)

Based on PA , Alias: Nylon, with high mechanical strength.High softening, high temperature resistance, high grinding efficiency, polishing smooth,slip, high concentricity, noise prevention, oil resistant, tolerant acid, alkali resistance,general solvent, good electrical insulation, self-extinguishing , non-toxic environmental protection, odorless, perfect weather resistance, easy dyeing.

## Glue

Chiyan: Waterborne Polyurethane Adhesive  
(non-toxic, transparent and environmentally friendly)



## Sand Grit

**Chiyan: pure natural sand**



### Brown corundum

Grade A brown corundum, high purity, wear resistance, less dust, good toughness.



### Green silicon carbide

High hardness, good grain shape, good compactness, high precision grinding products. Green silicon carbide is made from petroleum coke and quartz sand by melting and recrystallization with electric heating and chemical salt to turning green.



### Chrome corundum

High hardness, good toughness, low magnetic content, precision grinding product, 30% higher grinding force than brown corundum, high cleanliness.

## The Surface Layer

**Chiyan:**

The sand grains are evenly distributed, polished smooth and does not hurt the skin.





# 石头磨头

Stone Bit





Stone Bit 石头磨头



尺寸 Size (mm)	5.3*5.1	5.2*5.0	5.0*5.0
			
订单编号 Order No.	SC53510	SC52500	SC52501

Stone Bit 石头磨头

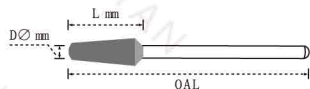

尺寸 Size (mm)	4.0*12	4.3*12	4.0*12	3.9*7.3
				
订单编号 Order No.	SC40120	SC40121	SC40122	SC39730











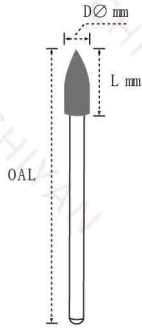

# 硅胶磨头

Silicon Polisher



### Silicon Polisher 硅胶磨头



推荐转速 Recommended r.p.m	10,000---15,000/min				8,000---12,000/min			
	粒度 / 尺寸 Grit / Size (mm)	F 4.0*12	F 6.0*16	F 10*20	F 10*24	F 10*17	F 13*20	F 14*17
包装 Packing (pcs) 12pcs								
订单编号 Order No.	SR2125	SR2135	SR2145	SR2025	SR2175	SR4035	SR4165	SR4015

### Silicon Polisher 硅胶磨头

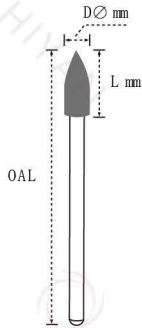

推荐转速 Recommended r.p.m	20,000---30,000/min				15,000---20,000/min			
	粒度 / 尺寸 Grit / Size (mm)	M 4.0*12	M 6.0*16	M 10*20	M 10*24	M 10*17	M 13*20	M 14*17
包装 Packing (pcs) 12pcs								
订单编号 Order No.	SR2123	SR2133	SR2143	SR2023	SR2173	SR4033	SR4163	SR4013

### Silicon Polisher 硅胶磨头

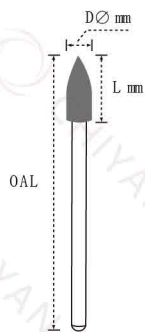

推荐转速 Recommended r.p.m	20,000---30,000/min				15,000---20,000/min			
粒度 / 尺寸 Grit / Size (mm)	C 4.0*12	C 6.0*16	C 10*20	C 10*24	C 10*17	C 13*20	C 14*17	C 15*17
包装 Packing (pcs) 12pcs								
订单编号 Order No.	SR2122	SR2132	SR2142	SR2022	SR2172	SR4032	SR4162	SR4012

### Silicon Polisher 硅胶磨头

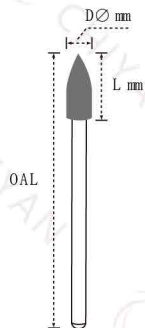

推荐转速 Recommended r.p.m	20,000---30,000/min				15,000---20,000/min			
粒度 / 尺寸 Grit / Size (mm)	XC 4.0*12	XC 6.0*16	XC 10*20	XC 10*24	XC 10*17	XC 13*20	XC 14*17	XC 15*17
包装 Packing (pcs) 12pcs								
订单编号 Order No.	SR2121	SR2131	SR2141	SR2021	SR2171	SR4031	SR4161	SR4011



# 迷你刷

Mini Brush



### Mini Brush 迷你刷

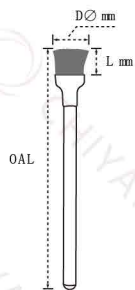

粒度 / 尺寸 Grit / Size (mm)	Nylon 6.6*49	Nylon 6.6*49	Nylon 6.6*49	Nylon 6.6*49	Nylon 6.6*49	Steel 4.9*54	Steel 11.6*54	Steel 20*60	Steel 20*60	Steel 20.7*42.8
订单编号 Order No.	CYM6649	CYM6650	CYM6651	CYM6652	CYM6653	CYM6654	CYM6655	CYM6656	CYM6657	CYM1162

### Mini Brush 迷你刷

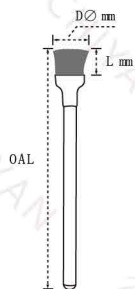

粒度 / 尺寸 Grit / Size (mm)	Floral wool 10.3*52.8	Black bristle 10.3*52.8	Nylon 11.4*50.4	White wool 10.3*55.1	Floral wool 10.6*54.3	Black bristle 11.7*52.5	Floral wool 11.7*52.5	Horse hair 11.7*52.5	Nylon 14.6*54.6	Sheepskin 21.2*43.5
包装 Packing (pcs) 12pcs										
订单编号 Order No.	CYM1155	CYM1157	CYM1159	CYM1158	CYM1154	CYM1156	CYM1153	CYM1152	CYM1160	CYM1161



轴心

Mandrel



## Sanding Cap Mandrel 砂帽轴心

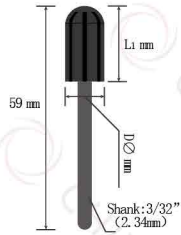

尺寸 Size (mm)	5*11	7*13	10*15	13*19	16*25		
订单编号 Order No.	CYM0006	CYM0007	CYM0008	CYM0009	CYM0010		

## Sanding Band Mandrel 砂圈轴心

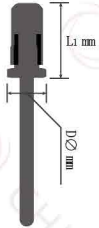

材质 Material	Steel			Stainless Steel			Carbide	Rubber	Carbide	Stainless Steel
尺寸 Size (mm)	3/32	3/32	1/8	3/32	3/32	3/32	3/32	3/32	3/32	3/32
订单编号 Order No.	CYM0001	CYM0002	CYM0003	CYM0004	CYM0005	CYM0006	CYM0007	CYM0008	CYM0009	CYM0010

